

MODEL PY-50b Nominal Tons 54.8

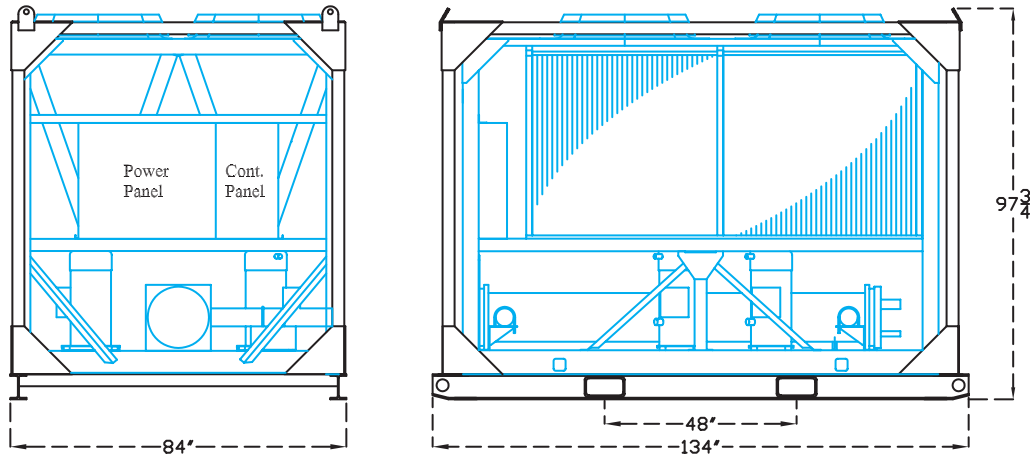

STANDARD FEATURES

- Compact rugged steel transport frame
- Fork lift tubes and tie down eyes
- Top mounted four point lifting lugs
- Industrial grade chiller suitable for commercial or process cooling duty
- Four compressors with dual independent refrigerant circuits
- Chilled liquid settings from 20-50°F
- Cam-lock water connections, 4"
- Automatic air vents
- Single point drain and fill connections
- Differential pressure gage with flow safety interlock
- Unit mounted capacity and flow charts
- Twist-lock connections for main power
- Enclosed main power breaker with lockable external handle
- Pump power output connection with pre-phased lockable breaker
- Shore power input connection, 115/60/1
- Complete DDC control center
- 40 Character Alpha-Numeric display
- Chilled water pump interface for automatic operation
- Push-to-test phase rotation indicator
- Network compatible controls interface

ELECTRICAL REQUIREMENTS

Main Power Breaker Range (Chiller Only): 125 Amps Min., 400 Amps Max.
With 15 HP Pump: 145 Amps Min., 400 Amps Max.
With 25 HP Pump: 165 Amps Min., 400 Amps Max.
Approximate Shipping Weight 6,870 lbs., Operating Weight 7,150 lbs.

MODEL PY-50 Nominal Tons 54.8

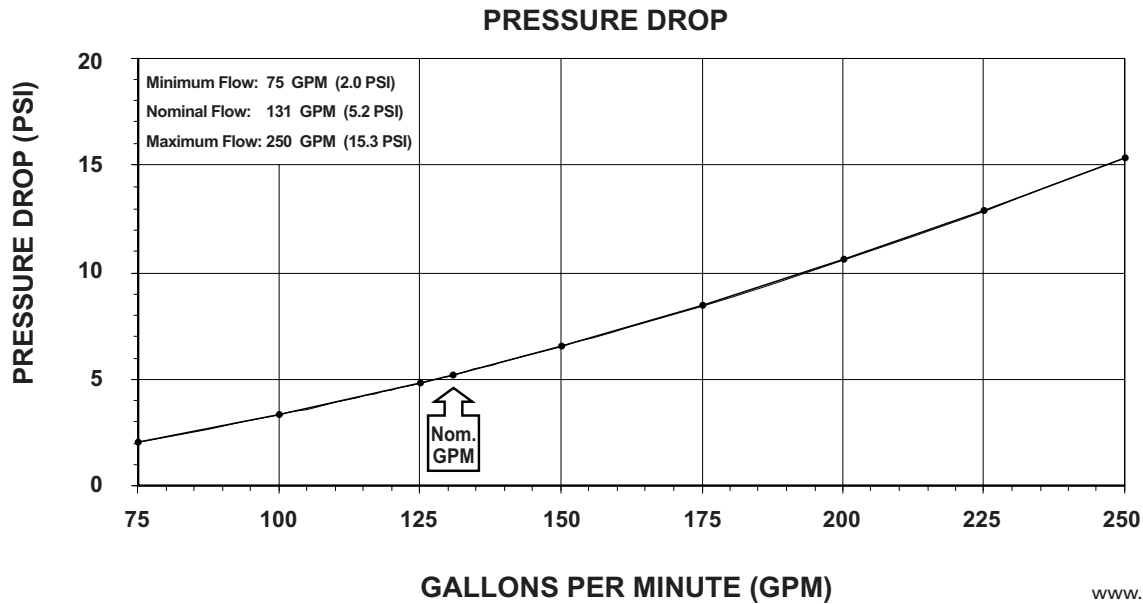
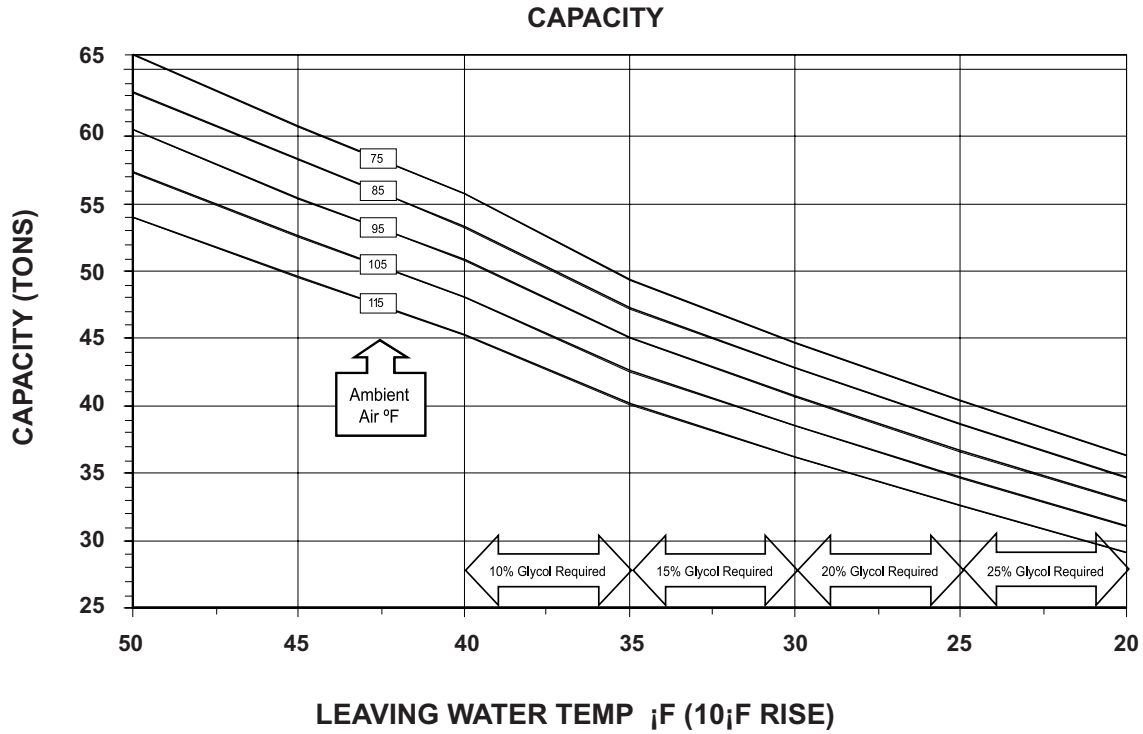

www.CAT-ElectricPower.com
© 2003 Caterpillar
All rights reserved.
Printed in U.S.A.