

STARTING SYSTEMS

Contents

Starting Systems	1
Starter Types.....	2
Electric Starting	3
Batteries	3
Lead-Acid.....	4
Nickel-Cadmium	4
Accessible Batteries	4
Maintaining Accessible Batteries	5
Battery Location and Hydrogen Venting.....	5
Battery Disconnect Switches (Battery Isolating Devices)	6
Battery Chargers	6
Charging Systems	7
Starter Motor.....	8
Continuous Cranking Time Limit with Electric Starter	
Motors	8
Starter Motor Cooling Period Between Cranking Periods	8
Starting System Wiring	8
Battery Cable Sizing (Maximum Allowable Resistance)	9
Connections/Proper Practices	10
Sample Wiring Diagrams	11
Pneumatic Starting (Air).....	13
Air Tank	13
Air Storage Tank Sizing	13

Air Starting Motor	14
Cranking Time Required	14
Air Consumption of the Starter Motor	15
Operation	15
Prelubrication Systems.....	15
Piping	16
Cleanliness	17
Testing	17
Hydraulic Starting	21
Hydraulic System Considerations	21
Starting Aids	22
Jacket Water Heaters	22
Battery Heaters.....	22
Ether.....	22
Manifold Heaters.....	23
Starting Smoke	23
Driven Load Reduction Devices.....	23
Emergency & Fast Starting.....	25
Reference Material	26

Foreword

This section of the Application and Installation Guide generally describes Starting Systems for Caterpillar® engines listed on the cover of this section. Additional engine systems, components and dynamics are addressed in other sections of this Application and Installation Guide.

Engine-specific information and data is available from a variety of sources. Refer to the Introduction section of this guide for additional references.

Systems and components described in this guide may not be available or applicable for every engine.

<ul style="list-style-type: none"> ● Standard ○ Optional - Not Available 	3126B	C7	C-9	C9	C-10/C-12	C11/C13	C-15/C-16	C15/C18	3412E	C27/C32	3500	C175	3600	G3300/G3400	G3500	G3600
Electric Starter	○	○	○	○	○	○	○	○	○	○	●	●	-	●	●	-
Pneumatic Starter	○	○	○	○	-	-	○	○	○	○	●	●	●	●	●	●
Pneumatic Starter with Prelubrication	-	-	-	-	-	-	-	-	-	-	○	○	●	-	○	●
Hydraulic Starter	-	-	-	-	-	-	-	-	-	-	○	-	-	-	-	-
Starting Aids																
Jacket Water Heaters	○	○	○	○	○	○	○	○	○	○	○	○	○	○	○	○
Battery Heaters	-	-	-	-	-	-	-	-	-	-	○	-	-	○	○	-
Ether Injection	○	○	○	○	○	○	○	○	○	○	○	○	○	-	-	-
Manifold Heaters	●	●	●	●	-	-	-	-	-	-	-	-	-	-	-	-

Information contained in this publication may be considered confidential. Discretion is recommended when distributing. Materials and specifications are subject to change without notice.

CAT, CATERPILLAR, their respective logos, "Caterpillar Yellow" and the POWER EDGE trade dress, as well as corporate and product identity used herein, are trademarks of Caterpillar and may not be used without permission.

Starting Systems

An engine starting system must be able to crank the engine at sufficient speed for fuel combustion to begin normal firing of the cylinders and keep the engine running. Startability of an engine is affected by factors such as ambient temperature, engine jacket water temperature, and lubricating oil viscosity. In addition, parasitic loads, usually associated with the driven equipment, can greatly influence the startability.

The diesel engine relies on heat of compression to ignite fuel. When the engine is cold, longer cranking periods or higher cranking speeds are necessary to develop adequate ignition temperatures. The drag due to the cold lube oil imposes a great load on the cranking motor. Oil type and temperature drastically alter viscosity; for instance, SAE 30 oil approaches the consistency of grease below 0°C (32°F).

Gas engines are spark ignited, but are also affected by the drag due to cold lube oil. Fuel composition varies widely from site to site. Fuels with low energy content will lengthen the cranking time as these fuels burn slower and cylinder firing during start-up is more erratic than when using natural gas.

SECTION CONTENTS

Starter Types.....	2	Hydraulic Starter.....	20
Electric Starter.....	3	• Considerations	
• Batteries		Starting Aids.....	21
• Motor		• Jacket Water Heaters	
• Wiring		• Battery Heaters	
Pneumatic Starter.....	12	• Ether Injection	
• Air Tank		• Manifold Heaters	
• Motor		Emergency & Fast Starting ..	24
• Piping			

Starter Types

There are three types of starting systems normally used for Caterpillar engines. They differ in the method of storing and recharging the energy required for restarting the engine.

Electric Starting Systems

Electrical systems use chemical energy stored in batteries. The batteries are automatically recharged by an engine-driven alternator or by an external source.

Air or Pneumatic Starting Systems

Pneumatic systems use compressed air in pressure tanks. The tanks are automatically recharged by an electric motor or engine-driven air compressor.

Hydraulic Starting Systems

Hydraulic systems use hydraulic oil stored in steel pressure vessels under high pressure. The vessels are automatically recharged by a small engine-driven hydraulic pump with an integral pressure relief valve.

Which One to Choose

The technology of all three of these systems is well developed. Any of the systems are easily controlled and can be configured to operate either manually or automatically.

Electric Starting

Electric starting is the most convenient starting system to use. Battery-powered electric motors utilize low voltage direct current and provide fast, convenient, push-button starting with lightweight, compact, engine-mounted components.

A motor contactor isolates the control logic circuits from high cranking currents. Storage of energy is compact; however, charging the system is slow and may make starting difficult in case of emergency.

Electric starting becomes less effective as the temperature drops. This is due to the loss of battery discharge capacity and an increase in an engine's resistance to cranking under those conditions.

Electric starting is the least expensive system and is most adaptable to remote control and automation. Refer to **Figure 1** and **Figure 2**.

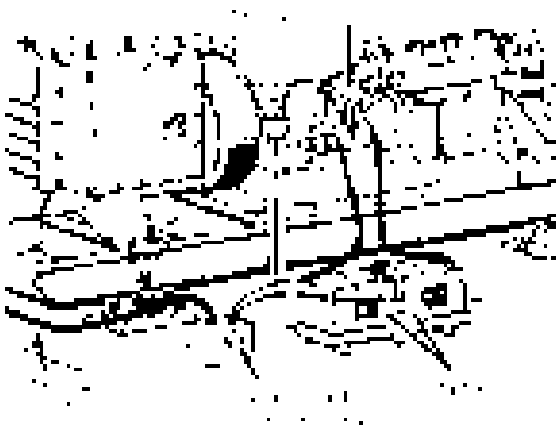

Figure 1

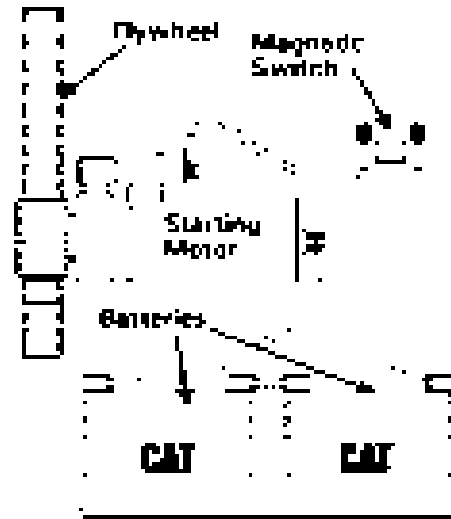

Figure 2

Water can damage the starter motor solenoid if it enters and is retained in the unit. To prevent this, engines stored outside should be provided with a flywheel cover. If possible, the starting motor should be mounted with the solenoid in an up position. This would provide drainage and prevent water from collecting in the solenoid.

Engines that are subject to heavy driven load during cold start-up should be provided with a heavy-duty starting motor. See section on Driven Load Reduction Devices.

Note: Marine and Petroleum engines use case-insulated 2-wire grounded starters and alternators.

Batteries

Batteries must store and discharge sufficient power to crank the engine long enough and fast enough to start the engine. A good rule of thumb is to select a battery package which will provide at least four 30-second

cranking periods (total of two minutes cranking) without dropping below 60% of the nominal battery voltage. An engine should not be cranked continuously for more than 30 seconds or starter motors may overheat.

Ambient temperatures drastically affect battery performance and charging efficiencies. Maintain 21°C (70°F) temperature to assure rated output. Battery temperature should not exceed 52°C (125°F). When operating in cold climates, the use of battery heaters is recommended. The heaters should be set to maintain battery temperature in the range of 21 to 32°C (70 to 90°F) for maximum effectiveness. The significance of colder battery temperatures is described in **Table 1** and **Table 2**.

All battery connections must be kept tight and coated with grease or other terminal protectant to prevent corrosion.

Lead-acid and nickel-cadmium batteries are typically used for electric starting systems.

Lead-Acid

Lead-acid batteries are readily available, have high output capability, and are relatively inexpensive.

Nickel-Cadmium

Nickel-cadmium batteries are costly, but have a long shelf life and require minimum maintenance. Because nickel-cadmium batteries are designed for long life, they may incorporate thick plates that decrease high discharge capability.

Consult the battery supplier for specific recommendations.

Accessible Batteries

Accessible batteries are batteries where the caps can be removed to allow access to check the electrolyte levels and to top off the electrolyte (use de-ionized or de-mineralized water only) within the cells of the battery.

It is **recommended** to use accessible type batteries in all Genset applications. Genset applications commonly use a constant charge such as a float charge during operation and the use of this type of constant charge shortens the life of the battery (if the battery is not maintained properly). The use of accessible type batteries allows for proper maintenance (electrolyte level check) and service to the batteries, maximizing the life of the batteries.

If an accessible design is not available, a non-accessible design can be used but must be replaced after 3 years of service. For warmer geographical regions, replace the non-accessible battery within 2 ½ years.

The table below lists the recommended accessible batteries along with their non-accessible counterpart.

Group Size	Accessible	Non-accessible
8D	101-4000	153-5720
4D	9X-9730	153-5710
4D	9X-9720	153-5700
31	115-2422 & 115-2421	9X-3404

Maintaining Accessible Batteries

Accessible batteries require periodic checks for proper electrolyte level. The electrolyte level should be covering the plates/grids ($\frac{1}{2}$ inch (13mm)) within the battery to maximize full charge transfer. If the liquid level is below the plates/grids, **only** add de-ionized water or mineral free water; never add battery acid to top off the volume, as the addition of extra acid will destroy the grids.

It is recommended to check the electrolyte level in the accessible batteries every 1000 hours. In warmer climates, check more frequently, such as every 500 hours to make sure the electrolyte level is $\frac{1}{2}$ inch (13mm) above the top of the separators.

Battery Performance			
Specific Gravity vs. Voltage			
Specific Gravity	% Charge	Voltage per Cell	Freezes °F (°C)
1.260	100	2.10	-70 (-94)
1.230	75	2.07	-39 (-56)
1.200	50	2.04	-16 (-27)
1.170	25	2.01	- 2 (-19)
1.110	Discharged	1.95	+ 17 (-8)

Table 1

Temperature vs. Output	
°F (°C)	% 80°F Ampere Hours Output Rating
80 (27)	100
32 (0)	65
0 (-18)	40

Table 2

Battery Location and Hydrogen Venting

Battery compartments should be configured to allow easy visual inspection for terminal corrosion and damage.

Install batteries in well-ventilated compartments only. Batteries emit hydrogen gas during the recharging cycle. Hydrogen gas is highly

explosive and very dangerous, even in small concentrations.

Hydrogen gas is lighter than air and rises harmlessly into the atmosphere unless trapped by a barrier, such as a ceiling, or within the battery compartment. Devices which can discharge electrical sparks or cause open flames must not be used where hydrogen gas is

likely to collect or in the path of escaping hydrogen gas.

Battery Disconnect Switches (Battery Isolating Devices)

Solid-state electrical devices can be damaged by the use of battery disconnect switches. These switches often interrupt load bearing circuits and at the instant of a circuit disconnect, transient currents and voltages can cause failure in any component whose transistors are not specifically protected.

Note: Only use battery disconnect switches that do not cause voltage transients (spikes).

Transient suppressers are to be used where applicable. Suppressers absorb current surges to prevent exposing these surges to sensitive electronic systems.

Battery Chargers

Various chargers are available to replenish a battery's charge.

Trickle chargers are designed for continuous service on unloaded batteries and automatically step down to milliampere current when the batteries are fully charged.

Note: Overcharging shortens battery life. Excessive water losses may indicate overcharging. Conventional lead-acid batteries require less than 59.2 mL (2 oz) of make-up water during each 30 hours of operation.

Float-equalize chargers are more expensive than trickle chargers and are used in applications demanding maximum battery life. These chargers include line and load regulation, and current limiting devices that permit continuous loads at rated output.

Chargers must be capable of limiting peak currents during cranking cycles or have a relay to disconnect during cranking cycles. Where engine-driven alternators and battery chargers are both used, the disconnect relay is usually controlled to disconnect the battery charger during engine cranking and running.

Engine-driven generators or alternators can be used but have the disadvantage of charging batteries only while the engine runs. Where generator sets are subject to long idle periods or many short stop-start cycles, insufficient battery capacity could threaten dependability.

Optimum charging volts for 12-volt battery vs. temperature for lead acid batteries, **utilizing a charger.**

Temp C	Temp F	MF CA/CA	MF CA/CA	SB	SB	Low SB Hybrid	Low SB Hybrid	AGM	AGM	GEL	GEL
		Min Volts	Max Volts	Min Volts	Max Volts	Min Volts	Max Volts	Min Volts	Max Volts	Min Volts	Max Volts
80	176	12.90	14.70	12.60	13.20	12.60	13.80	12.90	13.50	12.80	12.90
60	140	12.94	14.74	12.64	13.24	12.64	13.84	12.90	13.54	12.80	12.94
40	104	13.32	15.12	13.02	13.62	13.02	14.22	13.02	13.92	13.02	13.32
20	68	13.80	15.60	13.50	14.10	13.50	14.70	13.50	14.40	13.50	13.80
0	32	14.46	16.26	14.16	14.76	14.16	15.36	14.16	15.06	14.16	14.46
-30	-22	15.90	17.70	15.60	16.20	15.60	16.80	15.60	16.50	15.60	15.90

*Use Caterpillar Data Sheet, PEHJ-0073 to identify chemical construction of Caterpillar batteries to determine recommended charging voltages in previous table. For more information on battery charging and maintenance, refer to Special Instructions SEHS7633.

Charging Systems

Normally, engine-driven alternators are used for battery charging. When selecting an alternator, consideration should be given to the current draw of the electrical accessories to be used and to the conditions in which the alternator will be operating. An alternator must be chosen that has adequate capacity to power the accessories and charge the battery. If the alternator will be operating in a dusty, dirty environment, a heavy-duty alternator should be selected.

Consideration should also be given to the speed at which the engine will operate most of the time. An alternator drive ratio should be selected so that the alternator is capable of charging the system over the entire engine speed range.

Engine-driven alternators have the disadvantage of charging batteries only while the engine is running.

Brushless-type alternators are particularly vulnerable to losing their magnetic field after sitting idle for long periods. Refer to Special Instructions REHS4675 or Service Magazine SEBD1672 on how to "flash the field" to overcome this problem. Trickle chargers are available but require an A/C power source. Battery chargers using AC power sources must be capable of limiting peak currents during the cranking cycle or must have a relay to disconnect the battery charger during the cranking cycle. In applications where an engine-driven alternator and a battery trickle charger are both used, the disconnect relay must be controlled to disconnect the trickle charger during cranking and running periods of the engine.

Note: Marine and Petroleum engines use case-insulated 2-wire grounded starters and alternators.

Starter Motor

Continuous Cranking Time Limit with Electric Starter Motors

To avoid overheating of the starter motors, an engine should not be cranked continuously for more than 30 seconds.

Starter Motor Cooling Period Between Cranking Periods

Allow the starter motor to cool for two minutes before resuming cranking. If Marine Society certified, refer to applicable documents for cranking requirements.

Starting System Wiring

Power carrying capability and serviceability are primary concerns of the wiring system.

For correct size and correct circuit for starting system components, see wiring diagrams provided with the engine or the Operation and Maintenance manual. Sample diagrams are shown at the end of this section in **Figure 5** and **Figure 6**. All control wiring must be protected by fuses or a manual reset circuit breaker. The main battery cables need not be fused. These may or may not be shown on the wiring diagrams. Fuses and circuit breakers should have sufficient capacity and be readily accessible for service.

Other preferred wiring practices are:

- Use a minimum number of connections, especially with battery cables.

- Use positive mechanical connections.
- Use permanently labeled or color-coded wires.
- Position the batteries near the starting motor; short cables can be used to minimize voltage drop.
- A ground cable from the battery to starter is preferred for all applications. This ground cable is required for all marine and many petroleum applications.
- If frame connections are used, tin the contact surface. The path of the current must not include high resistance points such as painted, bolted, or riveted joints.
- Protect the battery cables from rubbing against sharp or abrasive surfaces.
- All battery connections must be kept tight and coated with grease or other protectant to prevent corrosion.
- The cranking batteries should always be securely mounted where it is easy to visually inspect and maintain. They must be located away from flame or spark sources and isolated from vibration. Batteries should be mounted level on non-conducting material and protected from splash and dirt. Short slack cables should be used to minimize voltage drops.
- Disconnect the battery charger when removing or

connecting battery leads. Solid-state equipment, like the electronic governor or speed switches, can be harmed if subjected to transients.

- For 3600 applications with electric starting, use separate batteries for starting and control systems, as shown in **Figure 5** at the end of this section.

Battery Cable Sizing (Maximum Allowable Resistance)

The start circuit between battery and starting motor, and the control circuit between the battery, battery-switch, and motor solenoid must be within maximum resistance limits shown in **Table 3**.

Note: Resistance values in **Table 3** include connections and contactors, except the motor solenoid contactor.

<i>Maximum Allowable Circuit Resistance</i>		
<i>Magnetic Switch and Series-Parallel Circuit</i>	<i>Solenoid Switch Circuit</i>	<i>Starting Motor Circuit</i>
12 Volt System .048 Ohm	.0067 Ohm	.0012 Ohm
24 Volt System .10 Ohm	.030 Ohm	.002 Ohm
32 Volt System .124 Ohm	.070 Ohm	.002 Ohm

Table 3

Fixed resistance allowances for contactors, relays, solenoid and switches are 0.0002 Ohm each.

Fixed resistance allowances for connections (series connector) are 0.00001 Ohm each.

The fixed resistance of connections and contactors is determined by the cable routing. Fixed resistance (Rf) subtracted from total resistance (Rt) equals allowable cable resistance (Rc).

$$R_t - R_f = R_c$$

With cable length and fixed resistance determined, select cable size using **Figure 3** and **Table 4**. Only full-stranded copper wire should be used. Arc welding cable is much more flexible and easier to install than full stranded copper wire cable, but welding cable is not as durable and will be damaged from corrosion in a much shorter time. The ground cable should also be added to the circuit's resistance calculations.

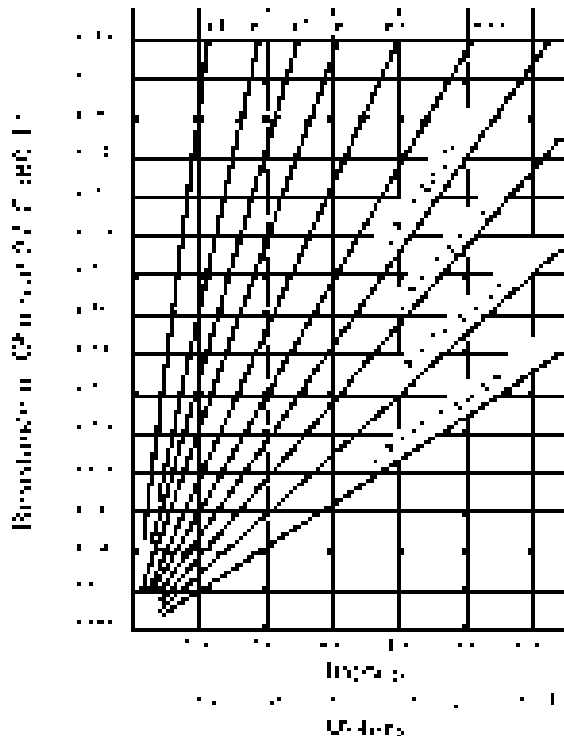

Figure 3

Maximum Recommended Total Battery Cable Length					
Cable Size		Direct Electric Starting			
AWG	MM ²	12 Volt		24 – 32 Volt	
		Feet	Meters	Feet	Meters
0	50	4.0	1.22	15.0	4.57
00	70	5.0	1.52	18.0	5.49
000	95	6.0	1.83	21.0	6.40
0000	120	7.5	2.29	27.0	8.24

Table 4

To meet cable length and resistance requirements, cable size is most important. To determine fixed resistance in a parallel circuit, only the long cables of the parallel circuit are counted. The paralleling cables are short enough to be insignificant in the resistance calculation. In the parallel battery connection shown in **Figure 4**, only the 56-inch and the 76-inch cable lengths need to be counted.



Figure 4

Connections/Proper Practices

Electrical connections are often a source of problems in any application. Shipboard, drill rig and any other electrical system that is exposed to salt air and water are especially susceptible because these elements are highly corrosive. Electrical connections are usually made of dissimilar metals. Corrosion is more destructive between dissimilar metals.

The following items are good practices for electrical system connections.

- When making electrical connections between wires, connect wires mechanically so tugging or pulling can be withstood without any other treatment of the joint.
- Coat the joint and the nearest portions of each wire with electrical solder.
- Do not expect solder to increase joint strength. The solder is for corrosion protection.

Pneumatic Starting (Air)

Air starting, either manual or automatic, is highly reliable. Torque available from air motors accelerates the engine to twice the cranking speed in about half the time required by electric starters.

Pneumatic starting is generally applied to large engines in work-boats, on land where facilities have existing plant air, or where a combustible gases may be present in the atmosphere.

The air system can be quickly recharged; but air storage tanks are prone to condensation problems and must be protected against internal corrosion and freezing.

Typical Pneumatic Starter

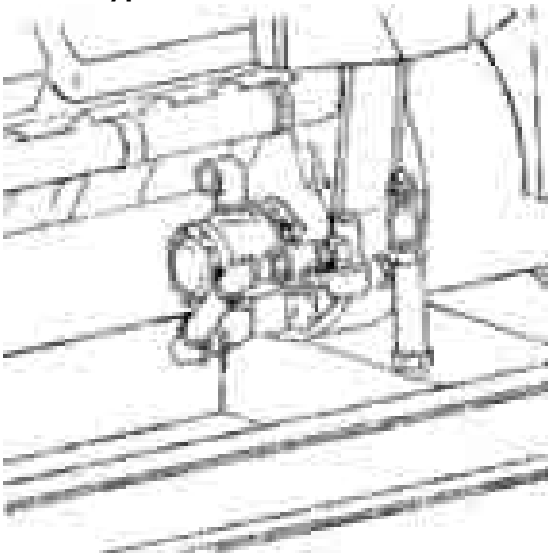

Figure 7

Air is usually compressed to 758 to 1723 kPa (110 to 250 psi) and is stored in storage tanks. Stored air is regulated to from 620 kPa (90 psi) to a maximum of 1550 kPa (225 psi)

depending on the engine and starter and piped to the air motor. Consult the Owners manual for the recommended regulation pressure for the engine model you are using. A check valve between the compressor and the air receiver is good practice, to protect against a failure of plant air that might deplete the air receivers' supply.

The air compressors that supply pneumatic starters are driven by external power sources such as electric motors and diesel or gasoline engines. A small emergency receiver (not supplied by Caterpillar) can be hand pumped to starting pressure under emergency conditions. A more common emergency backup will include an auxiliary diesel engine-driven air compressor package.

Air Tank

Air tanks are required to meet specific characteristics, such as the specifications of the American Society of Mechanical Engineers (ASME). Compressed air storage tanks must be equipped with a maximum pressure valve and a pressure gauge. Check the maximum pressure valve and pressure gauge often to confirm proper operation. A drain cock must be provided in the lowest part of the air receiver tank for draining condensation.

Air Storage Tank Sizing

Many applications require sizing air storage tanks to provide a specified number of starts without recharging.

This is accomplished using the following formula:

$$V_T = \frac{V_s \times T \times P_A}{P_1 - P_{MIN}}$$

Where:

V_T = Air storage tank capacity (cubic feet or cubic meters)

V_s = Air consumption of the starter motor (m³/sec or ft³/sec) —

Air Starting Requirements are in the TMI for model engine used.

If prelube is used its consumption must be added to V_s also.

T = Total cranking time required (seconds): If six consecutive starts are required, use seven seconds for first start (while engine is cold), and two seconds each for remaining five starts, or a total cranking time of seventeen seconds.

P_A = Atmospheric pressure (psi or kPa): Normally, atmospheric pressure is 101 kPa (14.7 psi).

P_T = Air storage tank pressure (psi or kPa): This is the storage tank pressure at the start of cranking.

P_{MIN} = Minimum air storage tank pressure required to sustain cranking at 100 rpm (psi or kPa) — Air Starting Requirements are in TMI for model used.

Example:

A 3516 Diesel Engine with electric prelube has the following:

Maximum air tank pressure = 1241 kPag (180 psig)

Minimum air to starter pressure = 620.5 kPag (90 psig)

Expected air line pressure drop = 207 kPag (30 psig)

Six consecutive starts. First start = 7 seconds the other 5 starts = 2 seconds

Average barometric pressure at this location = 100 kPa (14.5 psi)

Preconditioned engine installation.
(cfm x 0.02832 = m³/min)

Solution:

V_s = 0.40 m³/sec (14.1 ft³/sec)

T = 7 + (5 x 2) = 17 sec

P_A = 100 kPa (14.5 psi)

P_T = 1241 – 207 = 1034 kPag
(180 – 30 = 150 psig)

P_{MIN} = 620.5 kPag (90 psig)

Therefore:

$$V_T = \frac{0.4 \times 17 \times 100}{1034 - 620.5} = 1.64 \text{ m}^3$$

$$V_T = \frac{14.1 \times 17 \times 14.5}{150 - 190} = 57.93 \text{ ft}^3$$

Air Starting Motor

Cranking Time Required

The cranking time depends on the engine model, engine condition, ambient air temperature, oil viscosity, fuel type, and design cranking speed. Five to seven seconds is typical for an engine at 26.7°C (80°F). Restarting hot

engines usually requires less than two seconds. Most marine societies require a minimum of six consecutive starts for propulsion engines. Refer to the applicable marine society rules for current requirements for propulsion and other applications on marine vessels.

Note: Gas engines are generally a little harder to start. Even during hot starts, 10 second start attempts are sometimes needed. See Operation and Maintenance manual for starting recommendations.

Note: Some gas engine applications require purge cycles to vent unburned fuel before the next start attempt. Refer to local code or industry recommended practice.

Air Consumption of the Starter Motor

The starter motor air consumption depends on the same variables as mentioned in cranking time. The air pressure regulator setting also affects consumption. Normal pressure regulator setting is 759 kPa (110 psi). A higher pressure can be used, up to a maximum of 1550 kPa (225 psi), to improve starting under adverse conditions. Specific requirements for air starter consumption on various engine models are available from the TMI. This data assumes a bare engine (no parasitic load) at 10°C (50°F).

Operation

The supply of compressed air to the starting motor must be shut off as soon as the engine starts. This will prevent wasting starting air pressure and prevent damage to starter motor by over-speeding.

Prelubrication Systems

3600 Engines require prelubrication for all other models check Operation and Maintenance Manual. **Figure 8** shows a 3516 oil-field engine with an optional air starter and air prelubrication system. The system schematics in **Figure 9**, **Figure 10** and **Figure 11** show the included prelubrication system on 3600 engines. The prelubrication system is designed to provide lubricating oil to critical components before cranking and starting the engine.

Caterpillar furnishes an air cranking/air prelubricating system. This consists of an air-driven prelubrication pump that draws oil from the engine sump and forces it into the engine. This pump is driven by an air motor, through sequence valving runs, until a predetermined engine oil pressure shuts it off and turns on the air cranking motor. The additional air consumed by the prelude pump must be added to the starter motor air consumption to properly size the air receiver and air storage tank needed.

Oil-field engine applications that use the 2301A Electric Governor do not require prelubrication pumps because a properly wired 2301A Governor maintains engine speed at low idle speed until adequate oil pressure is in the lube system. When the engine starts and accelerates to low idle, it will stay at that speed until an electric switch is closed by engine oil pressure. The engine will then accelerate to rated speed.

Any solenoids used in the starting system must be DC to ensure starting during an AC power outage.

Piping

Air starter air supply piping should be short, direct and at least equal in size to the motor intake opening. Black iron pipe of seamless steel ASTM-A106 grade is preferred to prevent vibration induced fatigue from the starter to the piping. The piping requires flexible connections at the starter. In some larger engines, a flexible hose is included from Caterpillar. Deposits of oil and water will accumulate in the air receiver and at low spots in the piping. The accumulation of oil and water must be removed daily to prevent damage to the starting motors. Manual or automatic traps should be installed at the lowest parts of the piping and all piping should slope toward these traps.

If the engine operates at ambient air temperature below 0°C (32°F), and operates in a high humidity environment, an air dryer is needed to prevent condensed water from freezing in piping. When the same air is used for other purposes, e.g., engine controls, the air dryer is essential. A small quantity of alcohol in the starter air tank also prevents freezing if a dryer is not used. At temperatures below -18°C (0°F) consult the supplier.

During starting, an air pressure drop is associated with each air supply component. These components include the lubricator, strainer, relay valves and others.

Note: Vane-type air starters may also freeze during high humidity and low temperatures. Applications equipped with turbine-type air starters may also freeze in some low ambient conditions, but are less susceptible to motor freeze than vane-type air starters.

Dynamic losses range from 207 to 414 kPa (30 to 60 psi) depending on the engine model and supply line pressure. A minimum 759 kPa (110 psi) supply pressure is recommended for proper operation of the starting motors.

Starter/prelube supply and exhaust piping practice is critical when installing the engine. If restricted in excess the starter motor performance will be negatively impacted. Proper pipe diameter, length and directional changes such as elbows, tees and the like, all must be accounted for in the piping design. As with any site piping, industry standards and regulations for each application come into play and will define the appropriate piping material and safeguards necessary for the application. Combustible gas exhausting from starter motors must be piped away to designated area or to the atmosphere especially in gas service applications.

Hazardous locations will require CSA rating and regulations for starter/prelube attachment solenoid valves for control switching.

Blocking valves that positively disconnect the main air/gas supply when the starting/prelube cycles are completed may be necessary in some applications.

Cleanliness

Purge the compressed air lines of debris and loose weld material prior to initial startup. Dirty supply lines can damage starters and cause malfunctions of the relay valve. A damaged valve can open or keep open the main air supply lines and cause pinion and flywheel ring gear

teeth damage (pinion spinning while engaging).

Testing

Hydrostatically test the compressed air lines to at least 1.5 times the system working pressure, or to the requirements of the applicable regulatory agency.

3516 Oil-Field Engine with Optional Air Starter and Air Prelubrication

Figure 8

Typical Air Starting System

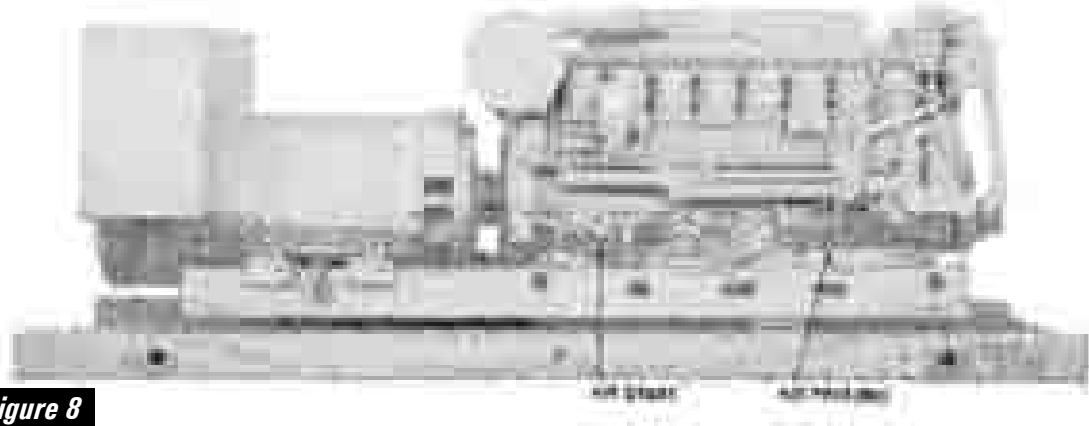
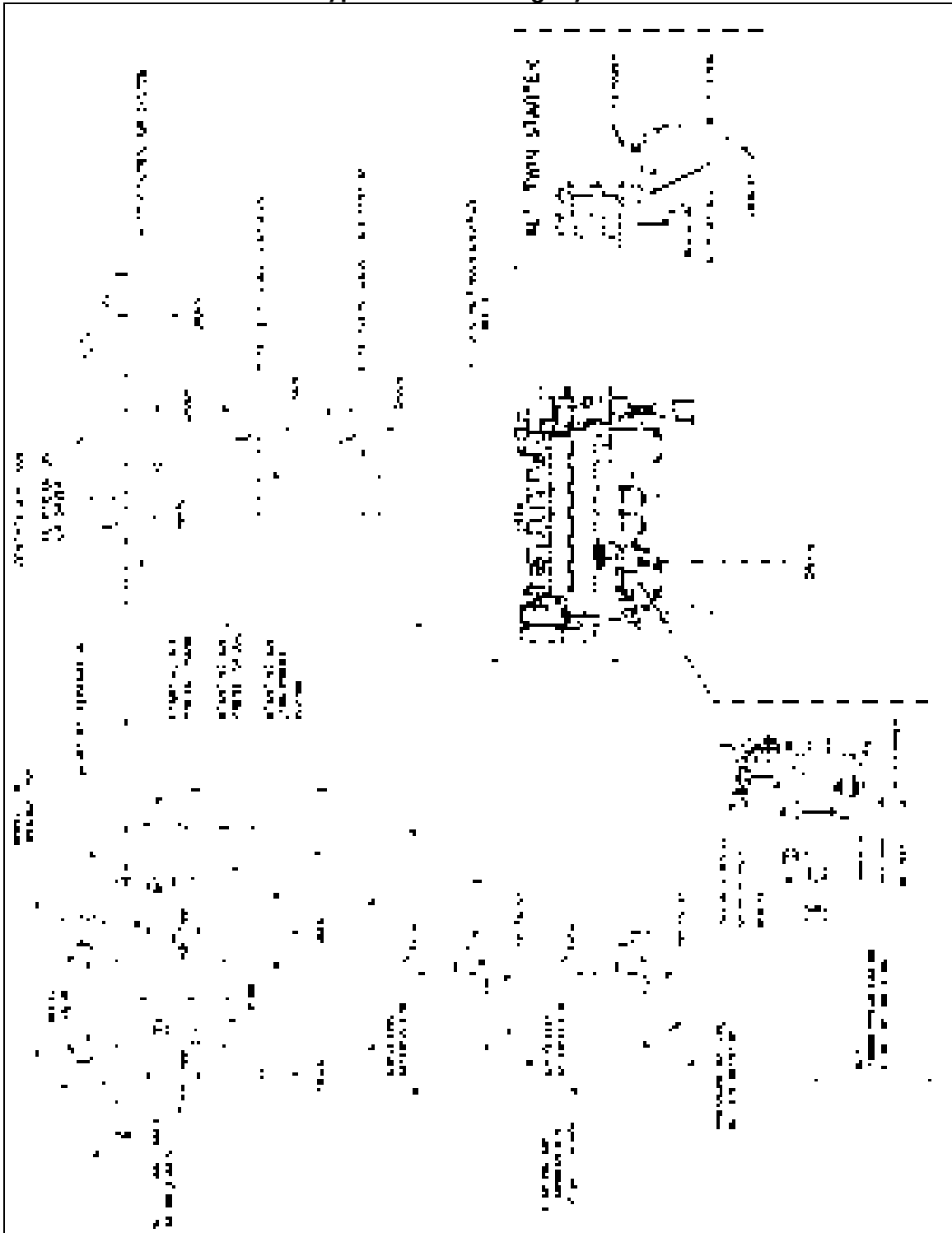

Figure 9

Air Starting Motor with Electric Prelube Pump and Electric Controls

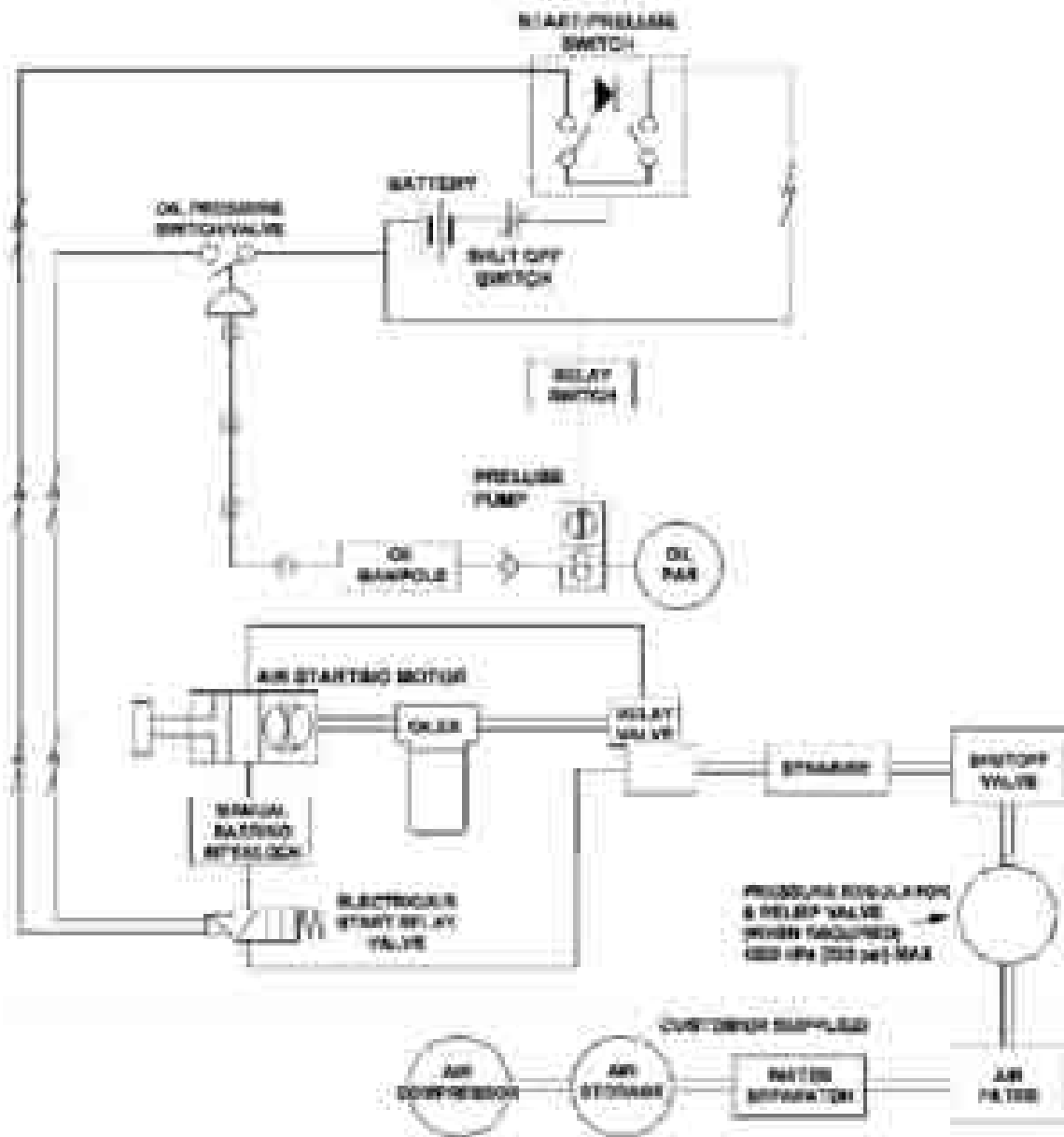

Figure 10

Air Starting Motor with Air Driven Prelube Pump and Electric Controls

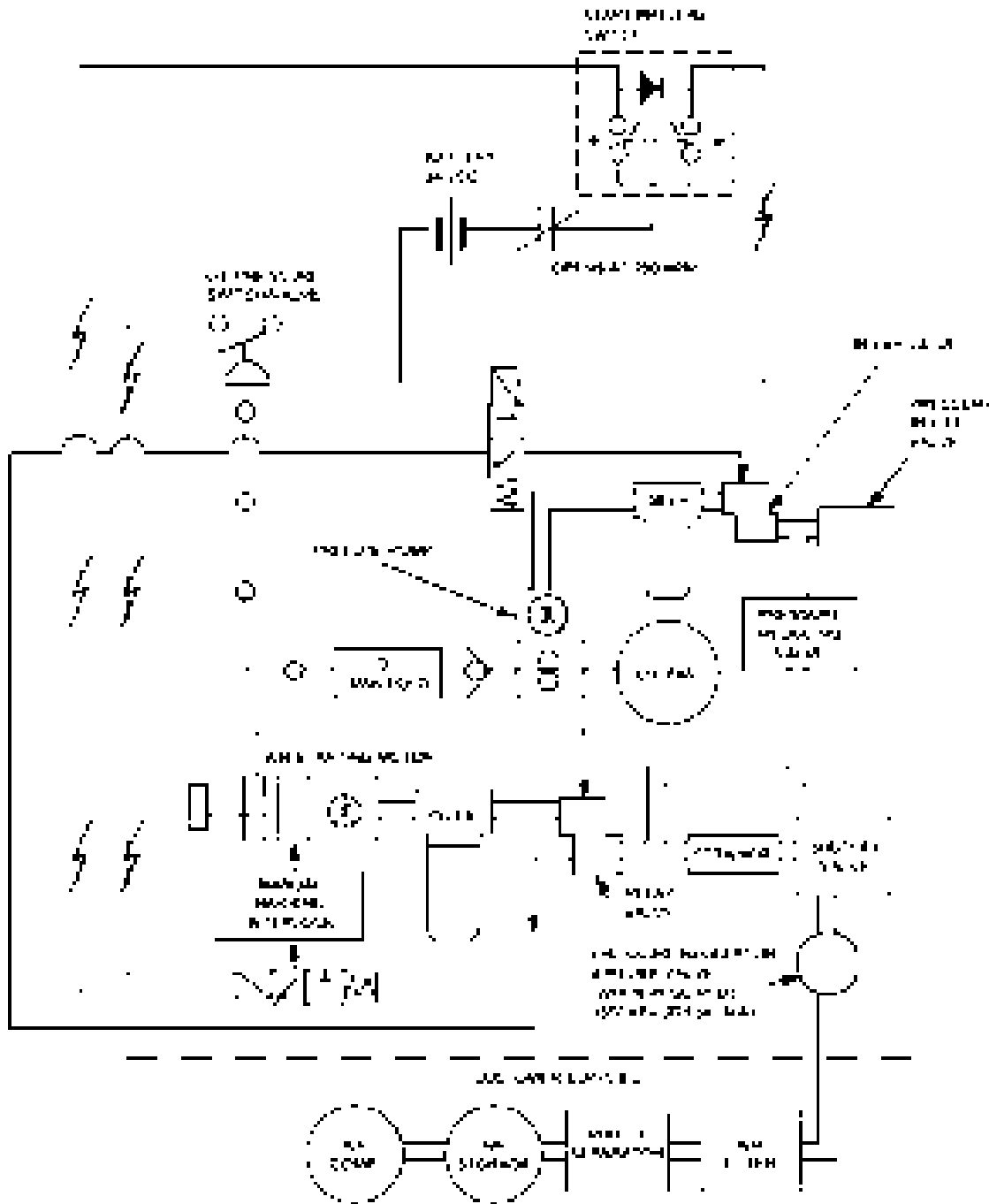

Figure 11

Hydraulic Starting

Hydraulic starting provides high cranking speeds fast starts, and is relatively compact. Recharging time, using the small engine-driven recharging pump, is fast.

Hydraulic systems can be recharged using a special hand pump, but process is very laborious.

The high pressure of the system requires special pipes and fittings and extremely tight connections.

Oil lost through leakage can easily be replaced, but because of high pressures in the accumulators, usually 20,700 kPa (3000 psi) when fully charged, recharging the accumulator(s) requires special equipment.

Hydraulic System Considerations

- Hydraulic starting is most often used where the use of electrical connections could pose a safety hazard.
 - Hydraulic starting systems are not available from Caterpillar for most models. They are available for 3508 and 3512 engines. Contact your local Caterpillar dealer for the nearest available supplier of other models.
 - If hydraulic accumulators are used, they must be very carefully protected from perforation or breakage. Hydraulic accumulators contain large amounts of stored mechanical energy.
- Repair to the system usually requires special tools.

Starting Aids

Diesel engines require the heat of compressed air in the cylinder to ignite the fuel. Below certain temperatures, the cranking system will not crank the engine fast enough or long enough to ignite the fuel. One or more commonly used starting aids, such as jacket water heaters and/or ether may be required to start the engine. In addition, engines with prelube requirements may require oil heaters. Refer to Operation and Maintenance manual for the engine model selected for cold weather procedures.

Jacket Water Heaters

Jacket water heaters are electrical heaters that maintain the jacket water at a temperature high enough to allow easy starting of the engine. More heaters of higher ratings may be required in areas of extremely cold temperature.

Jacket water heaters are used on both manual and automatic starting systems, but are essential for automatic starting below 21°C (70°F). Heaters precondition engines for quick starting and minimize the high wear of rough combustion, by maintaining jacket water temperature during shutdown periods.

Heaters thermostatically control jacket water temperature near 30°C (90°F) to promote fast starts. Higher temperatures accelerate aging of gaskets and rubber material.

Battery Heaters

Battery heaters are usually recommended in cold ambient

temperatures. The heaters should be set to maintain battery temperature in the range of 32 to 52°C (90 to 125°F) for maximum effectiveness.

Ether

Ether is a volatile and highly combustible agent. Small quantities of ether fumes added to the engine's intake air during cranking reduce compression temperature required for engine starting. This method can be used for starting of an engine at practically any ambient temperature. Ether starting aids are available on the smaller Caterpillar engines.

CAUTION: When other than fully sealed ether systems are used, ensure adequate ventilation for venting fumes to the atmosphere to prevent accidental explosion and danger to operating personnel.

The high-pressure metallic capsule-type is recommended for mobile applications. When placed in an injection device and pierced, ether passes into the intake manifold. This has proven to be the best system since few special precautions are required for handling, shipping, or storage.

Ether must be used only as directed by the manufacturer of the starting aid device. The ether system must be such that a maximum of 3.0 cc (0.18 cu in) of ether will be released each time the button is pushed. Caterpillar ether systems are designed to release 2.25 cc (0.14 cu in) of ether each time the system is activated. Excessive injection of ether can damage an

engine. Ether should not be released into a running engine.

Lighter fuels, such as kerosene, can ease the unaided cranking requirements slightly by lowering the compression temperature required for starting. These lighter fuels also slightly reduce horsepower delivered at any given fuel rack setting.

Excessive parasitic loads should be disconnected during engine cranking.

CAUTION: Under no circumstances should ether be used on any 3600 model engines or any engine that has an air inlet heater. Warning labels may be necessary if remote air intakes are used and the engine has an inlet heater. Labeling when remote air inlets are used is the responsibility of the customer or end user.

Manifold Heaters

Heat added to the intake manifold of an engine during cranking will significantly improve startability and reduce any white start-up smoke. Manifold heaters are used on small engines available from Caterpillar. Caterpillar does not offer manifold heaters on larger marine engines.

Starting Smoke

High performance engines are prone to have some white start-up smoke. The white smoke is composed of unburned fuel. Caterpillar engines have been designed to minimize this problem. Electronically controlled engines have a cold mode strategy built into the software to reduce start-up smoke.

Operators can do several things to improve the situation:

- Use jacket water heaters to raise the engine water temperature to 32 to 49°C (90 to 120°F) prior to starting.
- Keep warm-up idle speeds (rpm) low.
- Warm the air to the air cleaners and intake manifold.
- Diesel engines that are designed to have high output power, yet still be relatively lightweight, generally have low compression ratios; i.e., in the range of 12.5 to 16:1. This design factor makes them prone to misfire and run rough until the engine reaches normal operating jacket water temperatures of 80 to 93°C (175 to 200°F).

Driven Load Reduction Devices

Effect of driven equipment loads during cold weather engine starting must be considered. Hydraulic pumps, air compressors, and other mechanically driven devices typically demand more horsepower when they are extremely cold at start-up. The effect of this horsepower demand may be overcome by providing a means of declutching driven loads until the engine has been started and warmed up for a few minutes. This is not always easy or practical, so other means of relieving the load at cold start-up may be required if the engine-load combination cannot be started with

sufficient ease using the engine starting aids described earlier.

Some engine driven air compressors provide for shutoff of the air compressor air inlet during cold starting. This greatly decreases drag on the engine and improves cold startability. This approach can only be used when the air compressor manufacturer provides this system and fully approves of its use. Air compressor damage could result.

Emergency & Fast Starting

Some emergency and standby power applications require the ability for fast starting. Certain engine configurations are capable of supporting emergency power supply systems such that loads can be accepted within 10 seconds of a power outage.

The following list offers recommendations to achieve faster starting.

Note: If a project has a start time requirement, it is highly recommended that a **Start Time Analysis (STA)** is completed for the overall system. The STA provides a systems analysis on the basis of detailed input relating to the site conditions, intended electrical system components and the overall design of the critical power path. A factory supported start time analysis will be available only for C175, through the ASC inquiry system.

Note: The parameters listed below will improve starting but cannot guarantee starting in a certain number of seconds. Contact your Caterpillar dealer if a specific fast start time is required for your application.

- Maintain jacket water temperature at 49° C (120 ° F).
- Combustion air requirement of 21C minimum.
- Use dual jacket water heaters, if not circulating type or redundant.
- Starter must be able to crank engine above 110 rpm for ten seconds.
- Use dual heavy duty electric starters.
- Fully charged batteries.
- Heated batteries, if ambient temperatures are below 0°C.
- Depending on engine model, air starters may increase **or decrease** cranking speeds and thus **affect the** overall start time. Please consult your Caterpillar dealer for starter recommendations for your package.
- Use backup battery charger.
- Optional air starter.
- Air pressure adequate to crank engine above 110 rpm.
- Air tank and line volume large enough to crank engine above engine starting RPM.
- Set purge cycle time to zero for EMCPII engines.
- Continuous engine oil prelubrication must be installed and operating, if available on engine model.
- Fuel pressure must be up to the engine shutoff valve.
- The engine fuel shutoff must be installed as close the engine regulator as possible.
- The fuel shutoff valve must be energized at the same time as the starters.

- High-pressure gas systems will reach high idle faster than low-pressure gas systems.
- Low-pressure systems are more stable at high idle.
- Spark plugs and transformers must be properly maintained and operational.
- Oversized and high voltage generators increase the rotational inertia of the package and will slow start times.
- Engine driven radiator fans will slow package start times. Using oversized or high voltage generators in conjunction with engine driven fans may increase start times such that a 10 second start will not be achievable. If using an oversized or high voltage generator, consider using a remote radiator with electric driven fans.

Reference Material

Media List

The following information is provided as an additional reference to subjects discussed in this manual.

The following publications are available for order through your Caterpillar dealer.

Note: The information that is contained in the listed publications is subject to change without notice.

Note: Refer to this publication, the respective product data sheet, and to the appropriate Operation and Maintenance Manual for product application recommendations.

SEHS7633: Battery Maintenance Procedure

REHS4675: Procedure to Restore the Residual Magnetic Field on Brushless Alternators

SEBD1672: Service Magazine

